

# Model B3100 Guided Insulated Pipe Support

Heavy Duty,  
Base Mounted

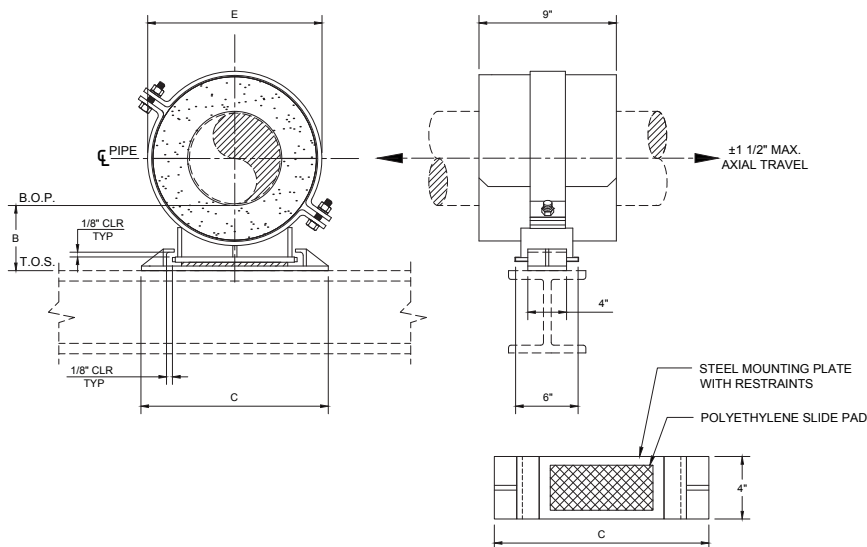
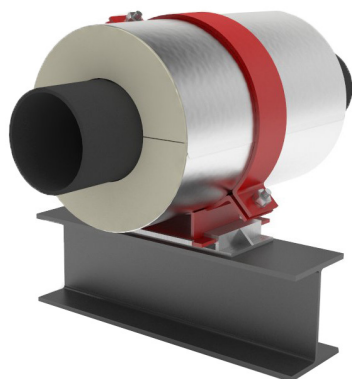

Contact factory for other dimensional, temperature, load, or axial travel requirements. If lateral load is greater than 20% of vertical load, contact factory. Available in all insulation thickness.

The load ratings represent average values obtained in accordance with accepted test methods and are subject to normal manufacturing variations. Dimensions and ratings are subject to change without notice.

Note: For higher load ratings, see: B3200 - For greater axial travel, see: B4100 - For lateral travel, see: B5100

Pipe Size	Vert. Load	Insul. Thk. = 1"			Insul. Thk. = 1-1/2"			Insul. Thk. = 2"			Insul. Thk. = 2-1/2"			Insul. Thk. = 3"			Insul. Thk. = 4"			Insul. Thk. = 5"		
		B	C	E	B	C	E	B	C	E	B	C	E	B	C	E	B	C	E	B	C	E
1/2	280	4	6	3.25	4	6.5	4.375	4	7	5.375	4	8.5	7	6	9	8	6	11	10	8	12.5	12.125
3/4	350	4	6	3.25	4	6.5	4.375	4	7	5.375	4	8.5	7	6	9	8	6	11	10	8	12.5	12.25
1	450	4	6.5	3.875	4	7	5	4	7.5	6.062	4	8.5	7	6	9	8	6	11	10	8	12.5	12.25
1 1/2	650	4	6.5	4.5	4	7	5.5	4	8.5	7.125	4	9	8.125	6	10	9.125	6	12	11.25	8	13.5	13.25
2	750	4	7	5	4	7.5	6.0625	4	8.5	7.125	4	9	8.125	6	10	9.125	6	12	11.25	8	13.5	13.25
2 1/2	920	4	7	5.5	4	8.5	7.125	4	9	8.125	4	10	9.125	6	11	10.125	6	12.5	12.25	8	14	14.5
3	1060	4	7.5	6.187	4	8.5	7.125	4	9	8.125	4	10	9.125	6	11	10.125	6	12.5	12.375	8	14	14.625
4	1680	4	8.5	7.25	4	9	8.25	4	10	9.25	4	11	10.25	6	12	11.375	6	13.5	13.375	8	15	15.625
5	2100	4	10	8.5	4	11	9.5	4	12	10.5	4	13	11.625	6	13.5	12.625	6	15	14.875	8	16.5	16.875
6	2550	4	11	9.5	4	12	10.5	4	13	11.625	4	13.5	12.625	6	14.5	13.625	6	16	15.875	8	17.5	17.875
8	3400	4	13.5	11.625	4	14	12.625	4	15	13.625	6	15.5	14.875	6	16.5	15.875	6	18	18.125	8	19	20.125
10	4000	4	15	13.875	4	15.5	15.125	4	16.5	16.125	6	17	17.125	6	18	18.125	6	19	20.125	8	20.5	22.125
12	4400	4	17	16.125	4	17.5	17.125	4	18.5	18.125	6	19	19.125	6	19.5	20.125	6	21	22.125	8	22.5	24.125
14	5000	4	17.5	17.125	4	18.5	18.125	4	19	19.125	6	19.5	20.125	6	20.5	21.125	6	22	23.125	8	23	25.125
16	5800	4	20.5	19.375	4	21	20.375	6	22	21.375	6	22.5	22.375	6	23.5	23.375	8	24.5	25.375	8	26	27.375
18	6400	4	22	21.375	4	22.5	22.375	6	23.5	23.375	6	24	24.375	6	24.5	25.375	8	26	27.375	8	27.5	29.375
20	6800	4	23.5	23.375	4	24	24.375	6	24.5	25.375	6	25.5	26.375	6	26	27.375	8	27.5	29.375	8	29	31.375
24	7200	4	26	27.375	4	27	28.375	6	27.5	29.375	6	28.5	30.375	6	29	31.375	8	30.5	33.375	8	32	35.375
30	9400	4	32.5	33.625	6	33	34.625	6	34	35.625	6	34.5	36.625	6	35	37.625	8	36.5	39.625	8	38	41.625
36	11000	4	36.5	40.125	6	37.5	41.125	6	38	42.125	6	38.5	43.125	6	39.5	44.125	8	41	46.125	8	42.5	48.125
42	12400	4	41	46.125	6	41.5	47.125	6	42.5	48.125	6	43	49.125	6	43.5	50.125	8	45	52.125	8	46.5	54.125

### Application:

Model B3100 is designed for use on:

- Hot water
- Cold water
- Chilled water
- Dual temperature
- Steam
- Air
- Gas
- Vacuum

Intended for installation on:

- Flat surfaces

### Temperature Range:

Standard: +40°F to +1200°F CalSil Insulation

Note: Up to 1800°F available upon request.

Cryogenic: -275°F to +275°F Urethane Insulation.

Add U after the model number (i.e., B3100U)

### Features:

- All pipe sizes
- Easy installation
- Eliminates welding to pipe
- Overlapping galvanized sheet metal jacket
- Insulating structural inserts for load transfer
- Stainless steel to UHMW polyethylene slide
- Other I.D.'s and/or O.D.'s available on request
- Factory mounted polyethylene slide pad on steel mounting plate

Performance test results on file:

Available upon request.

### Material Data:

- **B3100:** Applicable PSI spec. doc.: No. 209
- **Insulation:** Calcium silicate asbestos-free, treated with water repellent
- **Jackets:** Galvanized steel ASTM A-653
- **Glue:** Industrial contact adhesive
- **Structural Inserts:** High-density calcium silicate asbestos free, treated with water repellent
- **Steel Straps/Base:** Carbon steel ASTM A-36
- **Fasteners:** ASTM A-307 plated
- **Slide Pad:** UHMW Polyethylene (PTFE optional)
- **Coating:** Primer coated or hot dipped galvanized. Other coatings available upon request

Formal submittal sheets available